



- Accuracy class 0.2s or 0.5s for transformer operated and class 1 for direct connection
- Full 4-quadrant metering
- Active, reactive and apparent energy measurement
- Maximum demand, instantaneous values registration
- Auto-ranging power supply [3x57.7...230/100...400V]
- Multi-tariff, up to 8 tariffs
- Load profile measurement
- Data storage in non-volatile memory
- Power quality monitoring features
- Extended anti-tamper features
- Events logbook

# EPQS

for industry and utilities

**The EPQS meter** is a multifunctional device for the measurement of electric energy in four quadrants, which is approved in accordance with IEC 62053-11, IEC 62053-22, IEC 62053-21, IEC 62053-23. The meter operates in 3- or 4-wire networks and can be directly connected [accuracy class 1] or transformer operated [accuracy class 0.2s or 0.5s]. The EPQS meter can be easily incorporated into AMR systems. It has power quality monitoring capabilities and is designed to meet the most ultimate demands from utilities and other clients.

## Measuring

The Meter operates in three-phase 3- or 4-wire electricity networks and measures:

- Active energy [bi-directional] with accuracy class 0.2s or 0.5s [IEC 62053-22] for transformer operated and with accuracy class 1 [IEC 62053-21] for direct connection
- Reactive energy [in 4-quadrants]
- Apparent energy [delivered – received]
- Maximum demand with date & time
- Load profiles
- Instantaneous values [A, V, kW, kVAR,  $\cos \phi$  of each phases, Hz, temperature, battery voltage]
- Power quality

## Tariff module

the meter EPQS has an internal real-time clock with Li-ion or Super-Cap backup and a complex tariff structure [Time-Of-Use]:



• Number of energy tariffs	Up to 8 tariffs
• Number of maximum demand tariffs	Up to 8 tariffs
• Number of seasons	Up to 16 active seasons and 16 passive seasons
• Number of week profiles	Up to 32 different week profiles
• Number of day profiles	Up to 127 different day profiles
• Special days	A wlist of 256 holidays having links to appropriate day profile

## Data storage

The EPQS meter has 1 MB of non-volatile memory which allows to store metering data without the influence of power outages. Capacity of stored data:



• Total energy	[T1...T8, T0];
• Monthly energy	[T1...T8, T0], at least 54 months;
• Daily energy	[T1...T8, T0], at least 100 days;
• Cumulative maximum demand	[T1...T8];
• Monthly maximum demand	[T1...T8], at least 54 months, with date and time;
• Daily maximum demand	[T1...T8], at least 100 days, with date and time;
• Events logbook records	Up to 8192 events;
• Load profiles	Up to 8 channels;
• Instantaneous values	up to 16 programmable channels for any of 26 instantaneous values.

## Load Profiles

Average demand values are stored in the load profiles at the end of every integration period:

• Number of channels	8 [+A, -A, R1, R2, R3, R4, +W, -W]
• Load profile capacity	up to 341 days with integration period of 60 minutes
• Programmable integration period	from 30 sec to 60 min

## Communications

The meter has optical communication interface in accordance with IEC 62056-21. Optical communication interface allows the user to read data and program meters in the field or in the workshop.

The EPQS meter can have up to two independent electrical communication interfaces with protocol in accordance with IEC 62056-21 or IEC 62056-31, allowing connection of meters to an AMR system through external GSM/GPRS, RF, PSTN and LAN controllers:

- |  |                                      |
|--|--------------------------------------|
| • First electrical communication interface:                | 20 mA current loop or RS485 or RS232 |
| • [Optional] auxiliary electrical communication interface: | 20 mA current loop or RS485 or RS232 |

## Outputs

- Up to 8 electrical pulse outputs [50], programmable
- 2 LED test outputs for active and reactive energy
- [Optional] Up to 2 relay outputs controlled by:
  - External command via communication interface [for user disconnection];
  - 4 programmable intervals in the 24h period;
  - Tariff switching;
  - Special events from the log-book;
  - Demand overflow.
- [Optional] External backup power supply DC 12V for meter reading without power on the network

## Power Quality Monitoring

The EPQS meter can register several parameters of power quality according to IEC 50160. During the parameterization, the permissible range of electric network voltage and frequency fluctuations is set. The meter measures the average frequency value each 10 seconds and the average voltage value - each 10 minutes. Furthermore, it registers power outages in each phase.

- Power quality parameters are recorded in weekly reports;
- The meter memory can hold up to 256 weekly reports of power quality;
- Programmable thresholds and campaign start date.

## Security features

Hardware protection allows only authorized persons to access the meter:

- Two seals on main cover;
- Two seals on terminal cover;
- [Optional] optical communication interface sealing.

Software protection allows only authorized persons to program the meter with software for meter programming and data reading:

- Meter programming password protected [two levels]; if incorrect password is entered four times in a day, the communication interfaces will be locked for 24 hours. During that period communication is impossible.

The meter EPQS has an Events logbook with at least 8190 entries, registering the following events with date and time:

- Power outages;
- Reverse phase sequence;
- Missing of any phase voltage;
- Meter programming;
- Magnetic field influence;
- Unfavourable ambient temperature;
- Internal errors;
- Main cover openings;
- [Optional] terminal cover openings.



## Display

The EPQS meter is equipped with LCD [liquid crystal display]. LCD contains 4 strings [16 symbols in each string]. LCD displays any of data accumulated in meter and parameterization constants. Features:

- Cyclic [automatic] and static [manual] data scroll
- Load quadrant in each phase, phase sequence indicator
- Li-ion battery [Super-cap] status indication
- Menu control by pushbutton or [optional] light signals
- Selectable display language [English, Spanish, Russian or other upon request]
- OBIS code on LCD
- [Optional] LCD with backlight

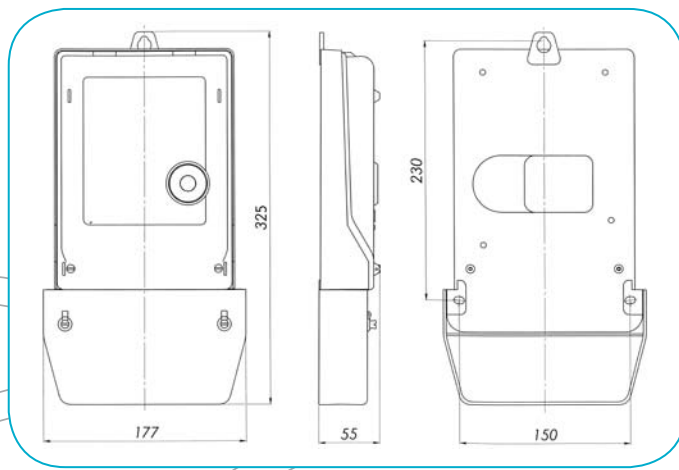

## Technical specifications

### Ratings

● System	Three-phase 4-wire or 3-wire
● Accuracy class for active and reactive energy	Class 0.2s, 0.5s or class 1 [for direct connected meters]
● Reference voltage, V:	
• 4-wire networks	3x57.7/100; 3x63.5/110; 3x69.2/120; 3x120/208; 3x127/220; 3x220/380; 3x230/400;
• Multi range	3x57.7 ...230/100 ...400
• 3-wire networks	3x100; 3x110; 3x120; 3x220; 3x230
● Reference [maximum] current:	
• Direct connected, A	10[100];
• CT operated, A	5[6]; 5[10]; 1[2]; 1[6]
● Current threshold	0.1% $I_b$ [0.4% $I_n$ , if direct operated]
● Reference Frequency, Hz	50 or 60
● Meter constant, imp/kWh [imp/kVArh]	≤130000
● Power consumption per phase:	
• In voltage circuit	< 0.9W < 2.5 VA
• In current circuit	< 0.3 VA/phase [< 0.05 VA/phase, if direct operated]
● Temperature ranges:	
• Meter operating	-40°C to +60°C
• Meter storage	-50°C to +70°C

### Internal real-time clock

● Accuracy	< 0.5 s/24h [T=23°C].
● Backup power supply of the clock	Li-ion battery or Super Cap
● Operation duration using only backup:	
• Li-ion battery	> 16 years
• Super Cap	> 7 days

### Case & Dimensions

● Case	UV stabilized polycarbonate
● Insulation	Protective class II
● Dimensions, mm	325 x 177 x 55
● Weight, kg	< 1.5



ELGAMA-ELEKTRONIKA  
 Visorių st. 2, 08300 Vilnius, Lithuania  
 Phone: +370 5 2375009, Fax +370 5 2375020  
 E-mail: marketing@elgama.lt,  
 www.elgama.eu

