



From SIMPLE

- Accuracy class 1.0 [B]
- Active energy measurement
- Single-tariff
- Optical communication interface
- Data storage in non-volatile memory

To SOPHISTICATED

- Accuracy class 1.0 [B]
- Active, reactive energy and maximum demand measurement
- Multi-tariff
- Optical and electrical communication interfaces
- Internal communication modules
- Load profiles and instantaneous values
- Internal relay for user disconnection
- Extended anti-tamper features
- Events logbook
- Internal real-time clock with changeable Li-ion battery or Super-Cap backup
- Relay output

GAMA 100

for residential and commercial metering

New generation single-phase static electricity meter GAMA 100 is developed for residential applications and is approved according to EN 50470-1, EN 50470-3, IEC 62052-11, IEC62053-21 and IEC 62053-23. The electricity meter satisfies the requirements of Directive 2004/22/EC of the European Parliament and of the Council of 31 March 2004 on measuring instruments.

GAMA 100 can be either simple, single-tariff or sophisticated, multi-tariff meter with extended functionality. Meter can be provided with various optional features - including reactive energy and maximum demand measurement, load profiling, possibility to connect meter to AMR system, extended anti - tamper capability, relay output.

Measuring

The meter operates in single-phase electricity networks and independently of current flow direction measure:

- Unidirectional or bidirectional [import - export] active energy with accuracy class 1.0 [B];
- [Optional] Reactive energy with accuracy class 2.0;

Tariff module

The GAMA 100 meter can be single-tariff or multi-tariff. The multi-tariff GAMA 100 modification has an internal real-time clock with Li-ion battery [[Optional] can be changeable without uninstalling meters from site] or Super-Cap backup and a complex tariff structure [Time-Of-Use]:

- [Optional] Maximum demand with programmable integration periods 1... 60 min.;
- [Optional] Measurement in two channels [in phase and neutral lines];
- [Optional] Instantaneous values [A, V, kW, kVAr, Hz];
- [Optional] Load profiles.

● Number of energy tariffs	Up to 4 tariffs
● Number of seasons	Up to 12 tariff seasons
● Number of week profiles	Up to 12-week profiles
● Number of day profiles	Up to 16-day profiles
● Special days	Up to 16 permanent and 64 movable days
● [Optional] Number of maximum demand tariffs	Up to 4 tariffs

Data storage

The GAMA 100 meter has non-volatile memory which allows to store metering data without the influence of power outages. Active and Passive tariff table. Capacity of stored data:

● Total energy	from installation date
● Monthly energy	of last 16 months
● Events logbook records	up to 100 records of each event type
● [Optional] Monthly maximum demand	last 16 months
● [Optional] Load profiles	up to 16 channels

Billing

At the end of the billing period, the billing period reset signal triggers the storage of the current values to the non-volatile memory. The billing period reset may be initiated:

● Manually	by pressing push button
● Automatically [programmable]	on decade days on 1/2 month on predefined day
● Remotely:	by communication interface

Load Profiles [Optional]

To help customers to meet deregulated market needs, the meter GAMA 100 can have programmable load profiles up to 16 channels [any of all measured energy, power type and average instantaneous value during the integration period]:

● Load profile capacity at 30 min. integration period	up to 654 days for 1 channel up to 150 days for 16 channels
● Programmable integration period	1, 5, 10, 15, 20, 30 or 60 min.

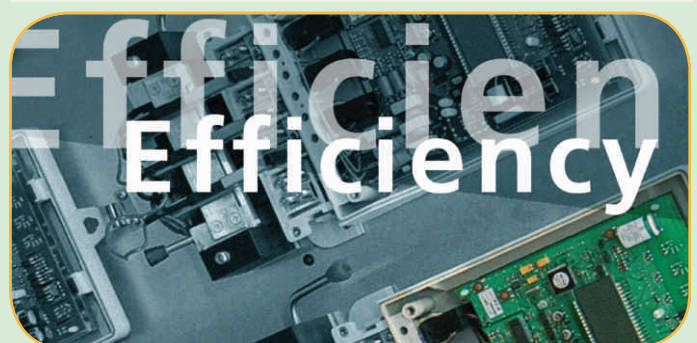

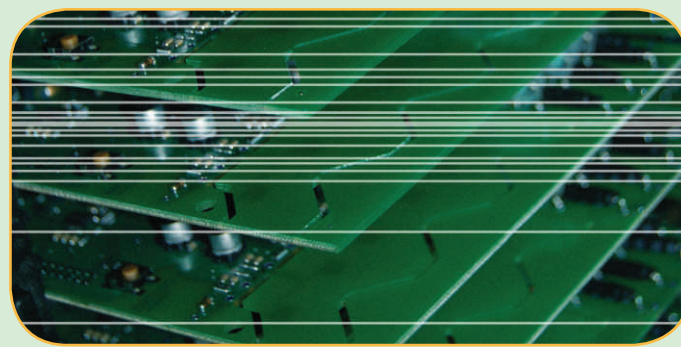
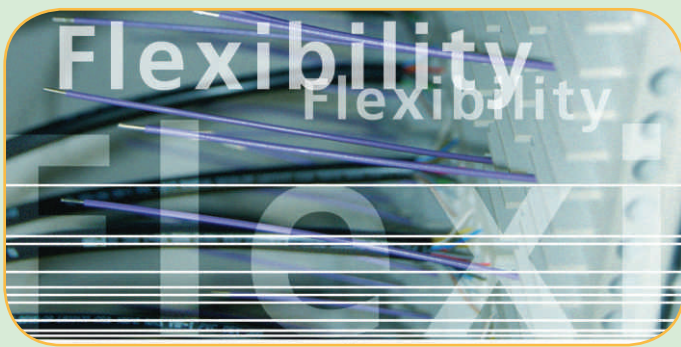

Communications

The meter has optical communication interface in accordance with IEC 62056-21 or DLMS . Optical communication interface allows the user to read data and to program the meter in the field or in the workshop.

[Optional] The GAMA 100 meter can have electrical communication interface [20 mA current loop or RS485] with protocol in accordance with IEC 62056-21, IEC 62056-31 or DLMS, allowing connection of meters to AMR system through external GSM/GPRS, RF, PSTN, and LAN controllers.

Outputs

- Electric pulse output [S0]
- LED test output
- [Optional] Relay, normally open contacts are connected:
 - When specified energy tariff is valid;
 - For two programmed periods during the 24 hour interval [periods are set in 15 minutes step].

Security features

Hardware protection allows only authorized persons to access the meter:

- Two seals on main cover;
- One seal on terminal cover;
- [Optional] Optical communication interface sealing;
- [Optional] current measurement in neutral.

Software protection allows only authorized persons to program the meter with software for meter programming and data reading:

- Meters programming is password protected; if incorrect password is entered four times a day, the communication interfaces will be locked for 24 hours. During that period communication is impossible.

The meter with internal clock has Events logbook registering the following events:

- Power outage log
- Change in number of phases log
- Power over-limit log
- Reverse current flow log
- Influence of magnetic field log
- Opening of meter cover log
- Opening of terminal cover log
- Clock setting log
- Parameter change log
- Internal error log

Power Quality Monitoring [Optional]

● Over-voltage	up to last 100 events with date & time
● Under-voltage	up to last 100 events with date & time
● Over-current	up to last 100 events with date & time

Display

The GAMA 100 meter is equipped with LCD [liquid crystal display]. LCD contains 8 digits with programmable decimal point: 8-5 for whole numbers and 0-3 digits for decimal numbers. LCD displays majority of data accumulated in meter and parameterization constants. Features:

- Cyclic [automatic] and static [manual] data scroll;
- Data indication on LCD during power outages;
- Reverse current flow indication;
- Li-ion battery [Super-cap] status indication;
- Menu control by pushbutton or [optional] light signals.

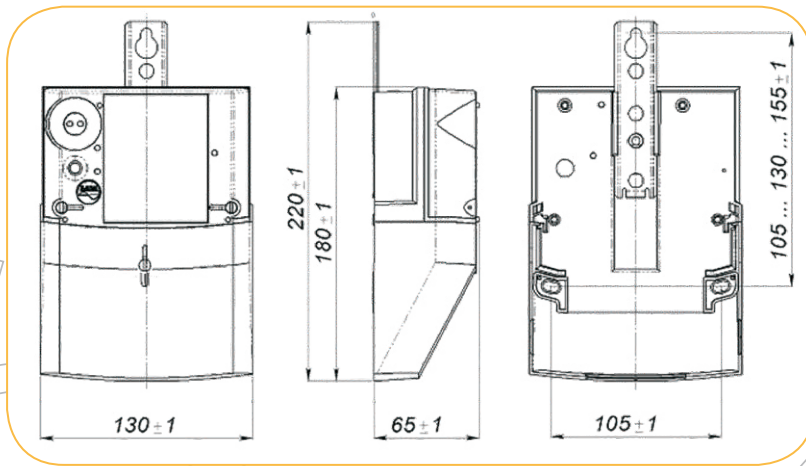

Technical specifications

Ratings

● System	Single-phase 2-wire
● Accuracy class:	
· For active energy	1.0 [IEC 62053-21], B [EN 50470-3]
· For reactive energy	2.0 [IEC 62053-23]
● Reference voltage, U_n	100V; 120V; 127V; 220V; 230V; 240V; special on request
● Reference [maximum] current, I_b [I_{max}]	5[40]A, 5[60]A, 5[80]A, 5[100]A, 10[60]A, 10[80]A, 10[100]A
● Current threshold	0.4% I_b
● Reference Frequency, f	50 or 60 Hz
● Meter constant, imp/kWh	1...19999, programmable
● Power consumption:	
· In voltage circuit	<0.75W; <1VA
· In current circuit	<0.05VA
● Temperature ranges:	
· Meter operating	-40°C...+70°C
· Meter storage	-40°C...+70°C

Internal real-time clock

● Accuracy	<0.5s/24 h (T=23°C)
● Backup power supply	Li-ion battery or Super-Cap [rechargeable]
● Operation duration using only backup:	
· Li-ion battery	>10 years
· Super-Cap	>7 days

Case & Dimensions

● Case	UV stabilized polycarbonate
● Insulation	Protective class II
● Protection class	IP 53 [Optional IP54]
● Dimensions, mm	180 x 130 x 65
● Weight, kg	0.6

ELGAMA-ELEKTRONIKA
 Visoriu st. 2. 08300 Vilnius, Lithuania
 Phone: +370 5 2375009
 Fax: +370 5 2375020
 e-mail: marketing@elgama.eu
 www.elgama.eu

