



From SIMPLE

- Accuracy class 1 or 2
- Active energy measurement
- Single-tariff
- Optical communication interface
- Data storage in non-volatile memory

To SOPHISTICATED

- Accuracy class 1 or 2
- Active energy and maximum demand measurement
- Multi-tariff
- Optical and electrical communication interfaces [AMR compatible]
- Data storage in non-volatile memory
- Internal real-time clock with Li-ion battery or Super-Cap backup
- Extended anti-tamper features
- Events logbook
- Relay output

GEM

for residential and commercial metering

The single-phase static electricity GEM meter is designed for residential applications and is approved according to IEC 62052-11 and IEC 62053-21. GEM can be either simple, single-tariff or sophisticated, multi-tariff meter with extended functionality. The meter can be provided with various optional features – including maximum demand measurement, the possibility to connect the meter to an AMR system, extended anti-tamper capability, relay output – to fulfill requirements of the most demanding customer.

Measuring

The meter operates in single-phase electricity networks and independently of current flow direction measure:

- Active energy with accuracy class 1 or 2 [IEC 62053-21]
- Instantaneous power
- [Optional] Maximum demand with programmable integration periods 15, 30, 60 min.

Tariff module

The GEM meter can be single-tariff or multi-tariff. the multi-tariff GEM modification has an internal real-time clock with Li-ion battery or Super-Cap backup and a complex tariff structure [Time-Of-Use]:

● Number of energy tariffs	Up to 4 tariffs
● Number of seasons	Up to 12 tariff seasons
● Number of week profiles	Up to 10-week profiles
● Number of day profiles	Up to 15-day profiles
● Special days	Up to 365 days
● [Optional] Number of maximum demand tariffs	Up to 4 tariffs

Data storage

The GEM meter has non-volatile memory which allows to store metering data without the influence of power outages. Capacity of stored data:

● Total energy	from installation date:
● Monthly energy	of last 16 months;
● Events logbook records	up to 10 records of each event type
● [Optional] Monthly maximum demand	last 16 months



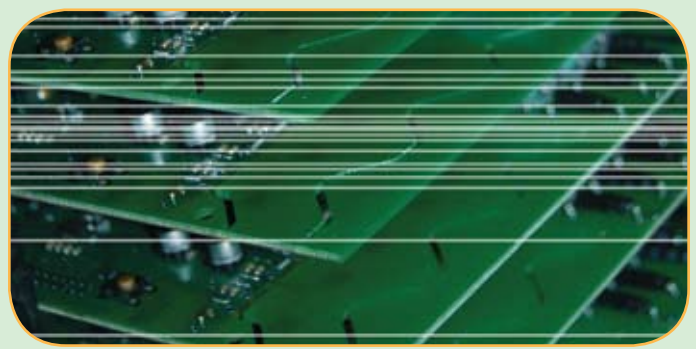

Communications

The meter has optical communication interface in accordance with IEC 62056-21. Optical communication interface allows the user to read data and to program the meter in the field or in the workshop.

[Optional] The GEM meter can have electrical communication interface [20 mA current loop or RS485] with protocol in accordance with IEC 62056-21 or IEC 62056-31, allowing connection of meters to AMR system through external GSM/GPRS, RF, PSTN, and LAN controllers.

Outputs

- Electric pulse output [50]
- LED test output
- [Optional] Relay, normally open contacts are connected:
 - When specified energy tariff is valid;
 - For two programmed periods during the 24-hour interval [periods are set in 15 minutes step].

Security features

Hardware protection allows only authorized persons to access the meter:

- Two seals on main cover;
- One seal on terminal cover;
- [Optional] Optical communication interface sealing.

Software protection allows only authorized persons to program the meter with software for meter programming and data reading:

- Meters programming is password protected; if incorrect password is entered four times a day, the communication interfaces will be locked for 24 hours. During that period communication is impossible.

The meter with internal clock has Events logbook registering the following events:

● Power outages	last 10 events with date & time;
● Meter programming	last 10 events with date & time;
● Magnetic field influence	last event with date & time;
● [Optional] Main cover openings	last event with date & time;
● [Optional] Terminal cover openings	last event with date & time.

Display

the GEM meter is equipped with LCD [liquid crystal display]. LCD contains 8 digits with programmable decimal point: 8-5 for whole numbers and 0-3 digits for decimal numbers. LCD displays majority of data accumulated in meter and parameterization constants. Features:

- Cyclic [automatic] and static [manual] data scroll;
- Data indication on LCD during power outages;
- Reverse current flow indication;
- Li-ion battery [Super-cap] status indication;
- Menu control by pushbutton or [optional] light signals.

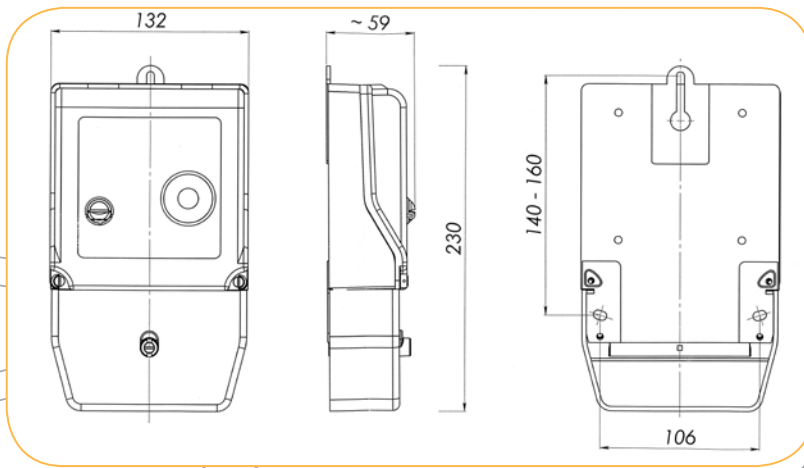

Technical specifications

Ratings

● System	Single-phase 2-wire
● Accuracy class	Class 1 or Class 2
● Reference voltage, U_n	100V; 120V; 127V; 220V; 230V; special on request
● Reference [maximum] current, I_b [I_{max}]	5[60] A; 5[85] A; 10[60] A; 10[100] A
● Current threshold	0.4% I_b
● Reference Frequency, Hz	50 or 60
● Meter constant, imp/kWh	2000 or 4000
● Power consumption:	
· In voltage circuit	< 0.75W; < 1 VA
· In current circuit	< 0.05 VA
● Temperature ranges:	
· Meter operating	-40°C to +60°C
· Meter storage	-50°C to +70°C

Internal real-time clock

● Accuracy	< 0.5 s/24 h ($T = 23\text{ °C}$).
● Backup power supply	Li-ion battery or Super-Cap [rechargeable]
● Operation duration using only backup:	
· Li-ion battery	> 16 years
· Super-Cap	> 7 days

Case & Dimensions

● Case	UV stabilized polycarbonate
● Insulation	Protective class II
● Dimensions, mm	230 x 132 x 59
● Weight, kg	0,95



ELGAMA-ELEKTRONIKA
 Visorių st. 2, 08300 Vilnius, Lithuania
 Phone: +370 5 2375009, Fax +370 5 2375020
 E-mail: marketing@elgama.lt,
 www.elgama.eu

